

Description

Radial piston Double pump model 12RBC & 12RBCE are arrangement with 3,5,7 or 9 pumping elements. in each outlet of the pump. External mounting type, Face Mounting. valve Control, Fixed delivery, Bi-Directional rotation of shaft. It is extension shaft for through drive with extension bracket assembly for coupling a low pressure pump having standard flanges.

Hydraulic Symbol

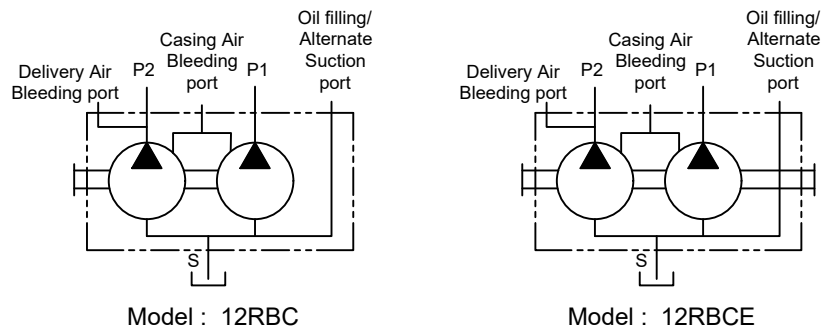

Technical Specification

Design	:	12RBC is a basic radial piston double pump with casing, 12RBCE is a radial piston double pump with casing & extension shaft. These pumps are valve controlled.
No. of pumping elements	:	3, 5,7 or 9 each at P1 & P2 port depending upon flow required.
Mounting interface	:	Factory standard, face mounting.
Direction of rotation	:	12RBC - Bi-directional pump 12RBCE - Depends upon the direction rotation of pump attached
Connection	:	Suction port (S) - G3/4 female Delivery port (P1 & P2) - G1/2 female
Speed range	:	300 to 2000 rpm
Flow and Pressure	:	Refer Performance table.
Torque limitation	:	Input drive shaft - 220 Nm Extension shaft - 130 Nm
Hydraulic medium	:	Mineral oil
Viscosity range	:	10 cSt to 100 cSt
Temperature range	:	-20°C to +80°C
Fluid cleanliness req.	:	ISO 4406 20/18/15 or better
Mass	:	12RBC3-25.5 kg, 12RBCE3-26 kg, 12RBC5-33 kg, 12RBCE5-34 kg, 12RBC7- 35.5 kg, 12RBCE7- 36 kg, 12RBC7-39 kg, 12RBCE7-40 kg.

Unit Dimension

Dimensions in mm

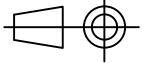

Model : 12RBC3

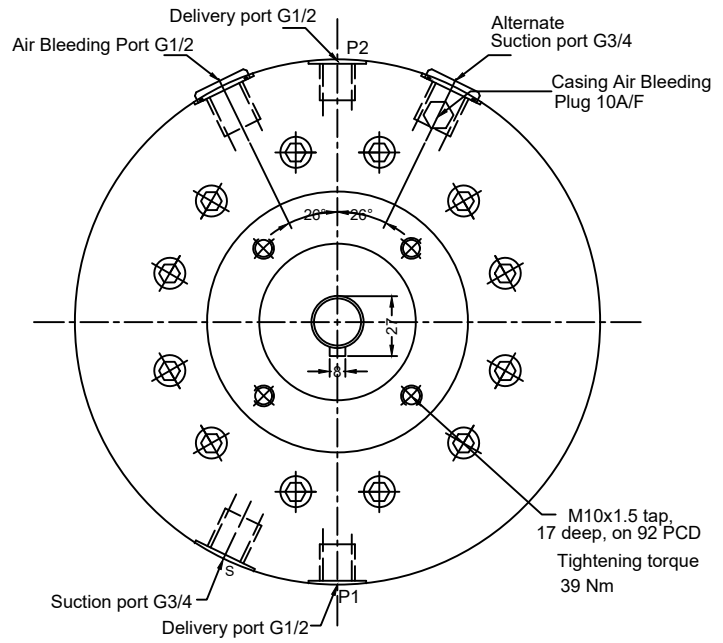
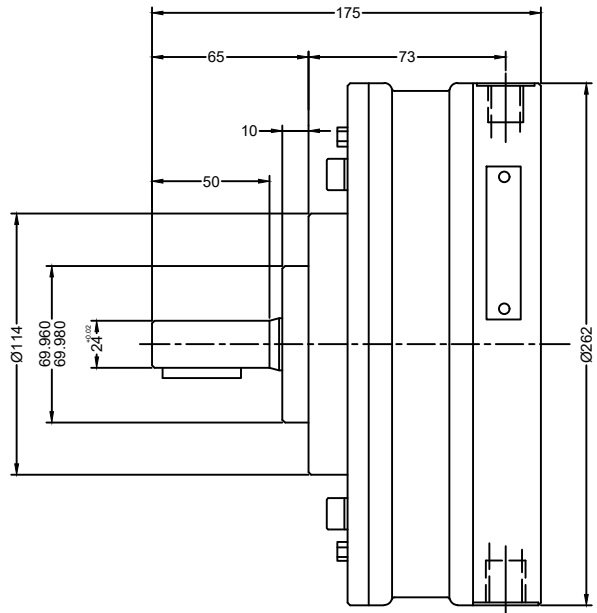

Model : 12RBCE3

Extension Bracket (for through drive)

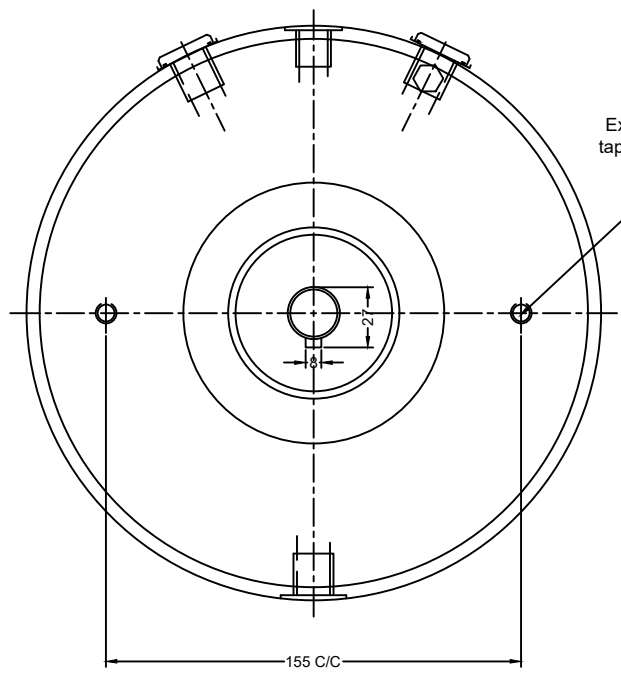

Extension Bracket Mounting
taped holes M16 tap, 20 deep
2 nos.
Tightning torque 77 Nm

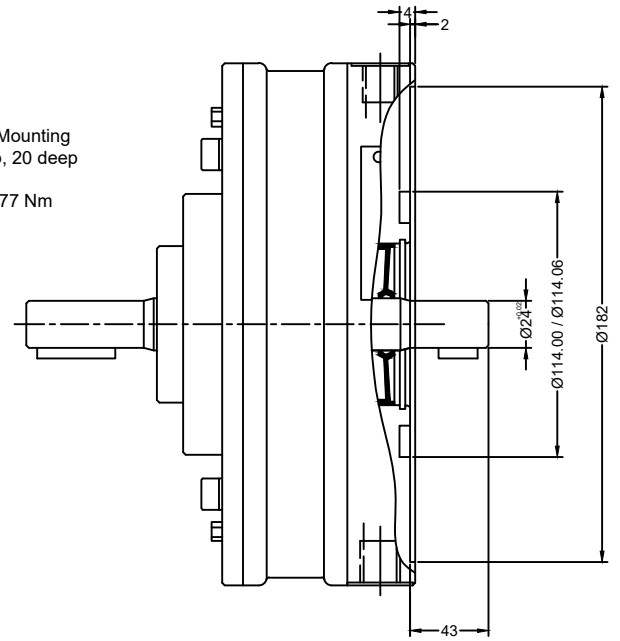

Unit Dimension

Model : 12RBC5/7/9

Dimensions in mm

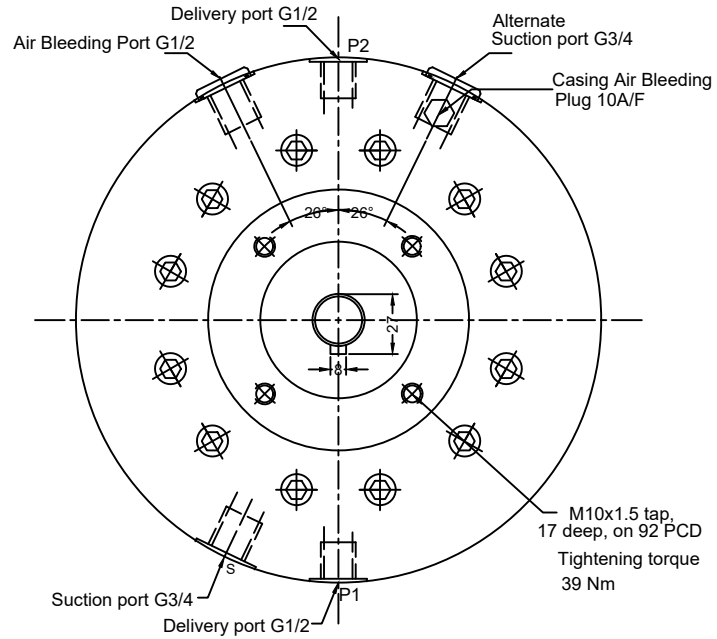
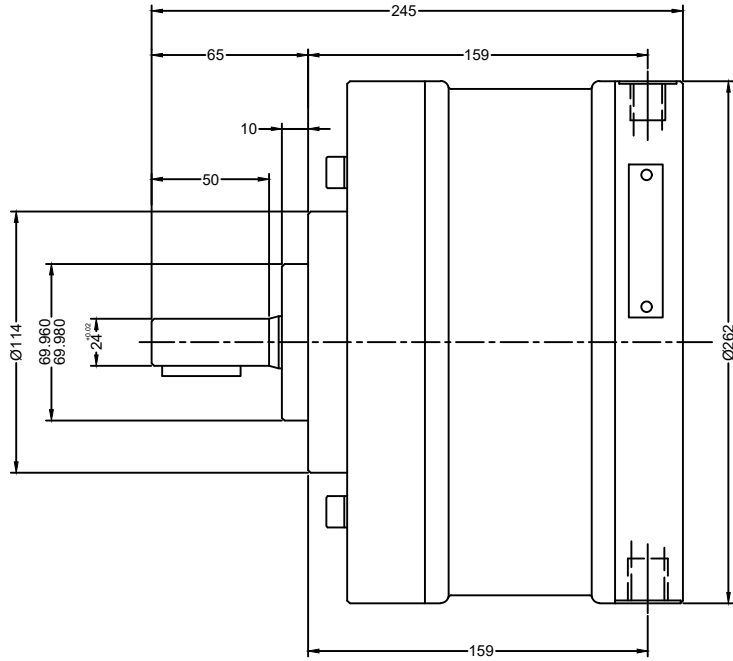
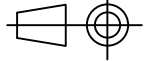

Model : 12RBCE5/7/9

Extension Bracket (for through drive)

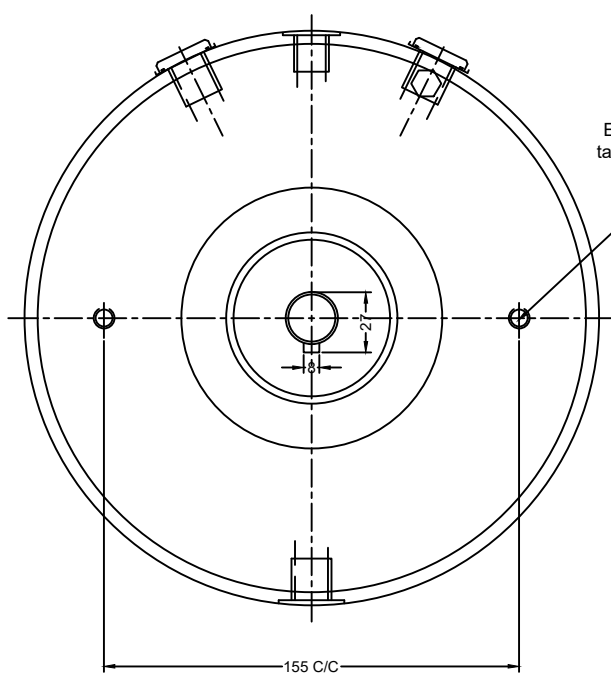

Extension Bracket Mounting
taped holes M16 tap, 20 deep
2 nos.
Tightning torque 77 Nm

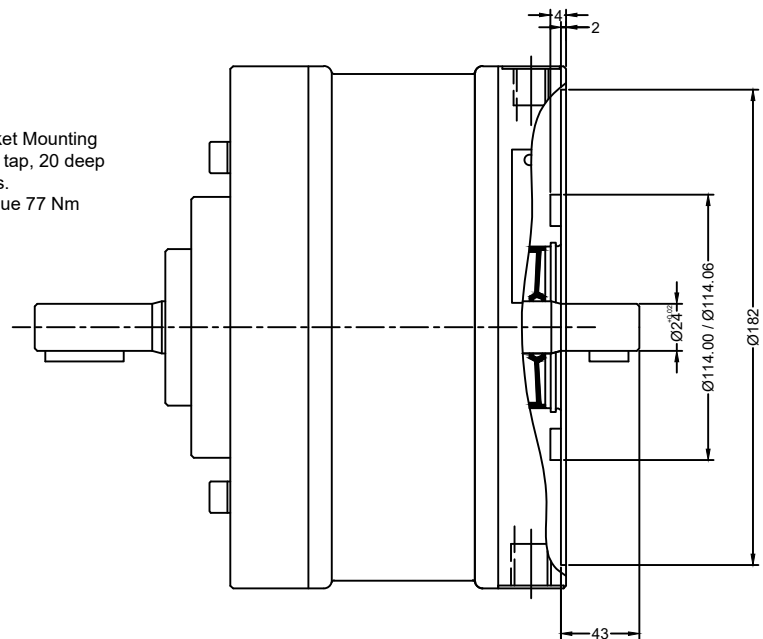

Performance Table

No. of Pumping Elements per section	Element Type	Geometrical displacement in cm ³ /r	Pump Output in l/min at 1450 rpm per section	Max Operating pressure in bar	Pressure in bar							
					50	100	150	200	250	300	315	400
					Power required for drive the pump in kW							
3	A	4.62	6.3	400	0.66	1.31	1.97	2.63	3.28	3.94	4.14	5.25
5		7.70	10.5		1.09	2.19	3.28	4.38	5.47	6.57	6.89	8.75
7		10.78	14.7		1.53	3.06	4.60	6.13	7.66	9.19	9.65	12.25
9		13.85	18.9		1.97	3.94	5.91	7.88	9.85	11.82	12.41	15.76
3	B	6.03	8.2	315	0.86	1.71	2.57	3.43	4.29	5.14	5.40	
5		10.05	13.7		1.43	2.86	4.29	5.72	7.15	8.57	9.00	
7		14.07	19.2		2.00	4.00	6.00	8.00	10.00	12.00	12.6	
9		18.10	24.7		2.57	5.14	7.72	10.29	12.86	15.43	16.21	
3	C	7.63	10.4	250	1.09	2.17	3.26	4.34	5.43			
5		12.72	17.3		1.81	3.62	5.43	7.23	9.04			
7		17.81	24.3		2.53	5.06	7.60	10.1	12.6			
9		22.90	31.2		3.26	6.51	9.77	13.02	16.28			

1kW = 1.3410 hp

Note : Torque limitation - The sum of torque used for the piston pump and torque used at extension shaft end should not exceed 220 Nm (11 kW at 1450 rpm)

Ordering Code

