

Description

Throttle cum check valve modular construction Model TCM 06 and TCM 10, Construction of this valve is modular, Spool type, Non pressure compensated valve. It is flow control valve and therefor offer constant flow for a given setting. Only if pressure drop across the throttle passage is constant. The valve can be convert from Meter IN to Meter OUT condition. The valve is available with check facility port A, B or AB.

Hydraulic Symbol

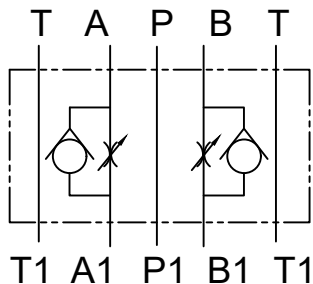

Model : TCMAB**

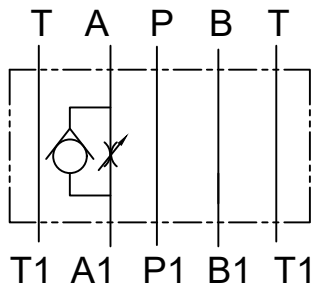

Model : TCMA**

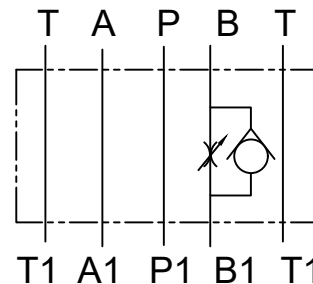

Model :TCMB**

Technical Specification

- Design : Modular Construction, Spool type, Non pressure compensated valve.
- Mounting interface : Subplate mounting modular ISO 4401-AC 05-4-A, IS10187, DIN24340
- Mounting position : Optional
- Flow Direction : For ports P & T free flow in either direction.
For ports A & B refer hydraulic symbol.
- Working Pressure : 315 bar for all ports .
- Flow handling capacity : CIM06 - 40 l/min and CIM10 - 100 l/min.
- Hydraulic medium : Mineral Oil.
- Viscosity range : 10cSt to 380cSt.
- Temperature range: -20°C to +80°C
- Mass : CIM06AB/A/B - 1 kg, CIM10AB - 2.1 kg, CIM10A/B - 2 kg,

Ordering Code

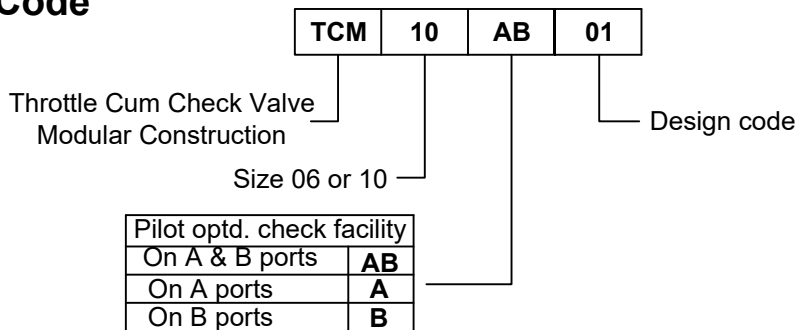

Unit Dimension

Dimensions in mm

Model : TCM06AB

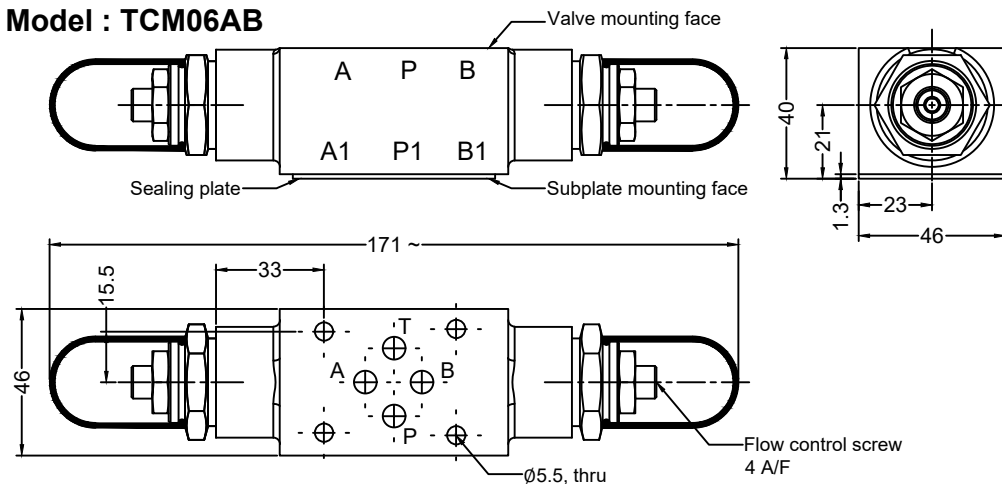

**Subplate Mounting Interface
TCM06****

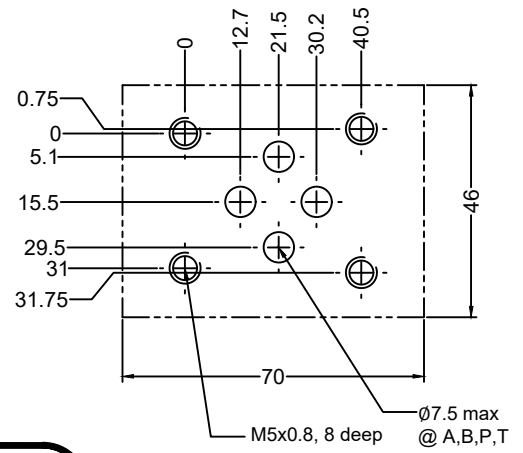

Model : TCM06A

Model : TCM06B

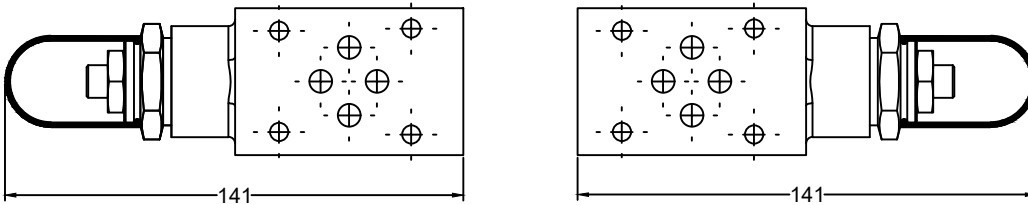

Model : TCM10AB

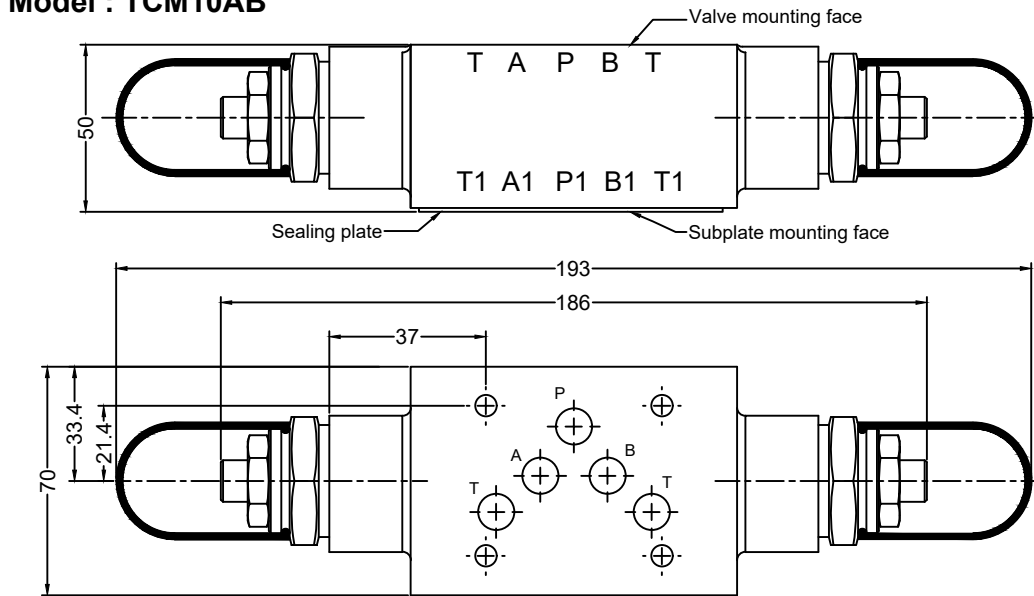

**Subplate Mounting Interface
TCM10****

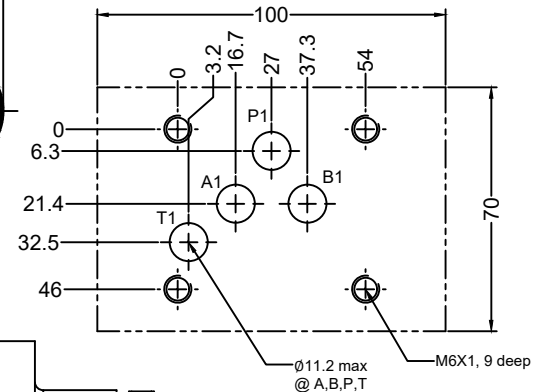

Model : TCM10A

Model : TCM10B

